

Boston

6.5³

6.5

5.5

4.5

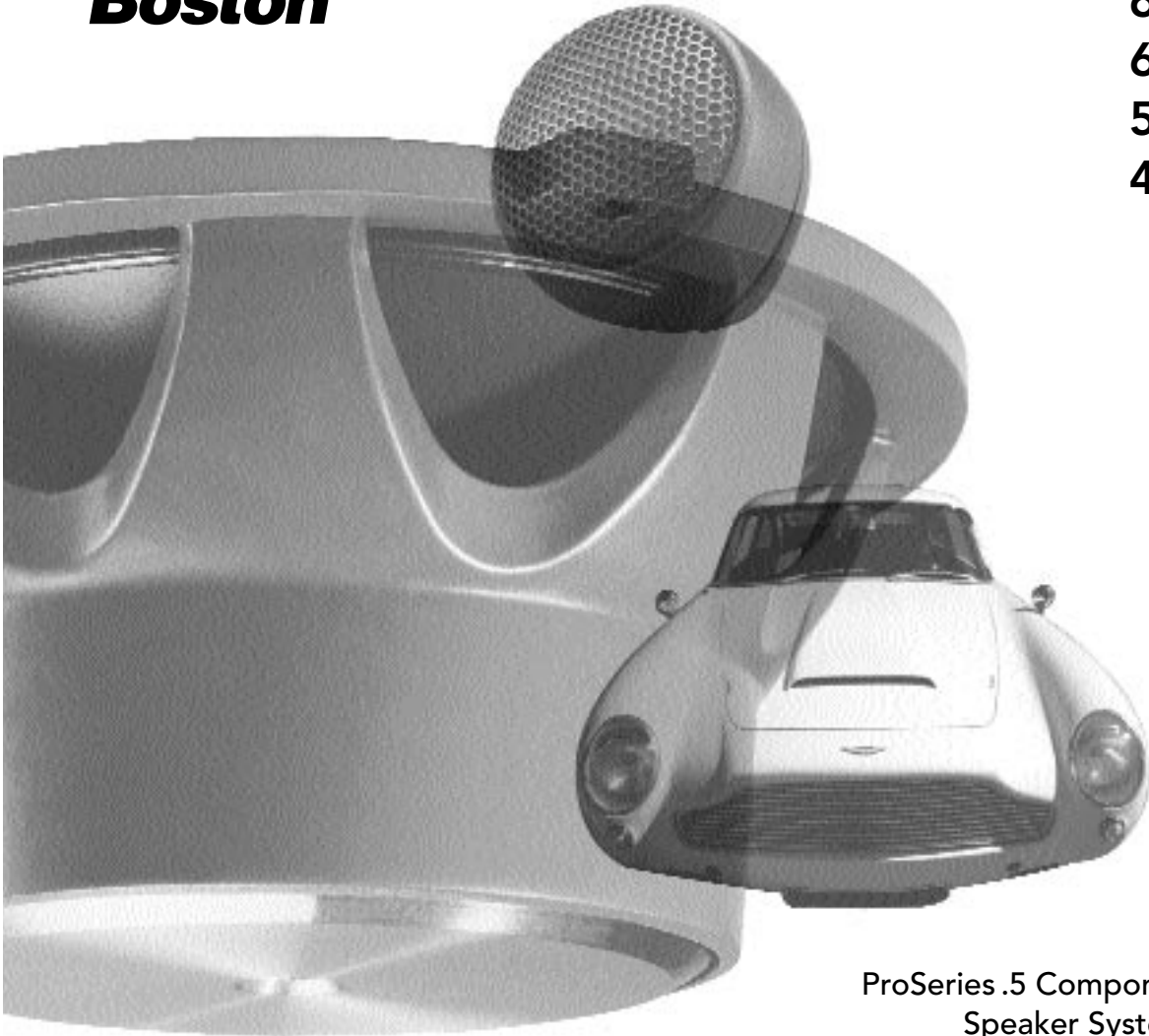

ProSeries .5 Component
Speaker Systems
Installation Manual

Boston

Table of Contents

Warning	2
System Contents	3
System Placement	4
Tweeter Installation	6
Woofers Installation	9
Crossover Installation	12
System Wiring	13
Specifications	16

Congratulations!

You have purchased the finest automotive component system the industry has to offer. Installed correctly, your ProSeries system will offer unprecedented performance for many years to come.

Warning

This manual explains only the assembly and placement of the various components, not the techniques required to perform the installation. If you do not have the experience these procedures require, we strongly recommend you consult your Boston Acoustics dealer about professional installation.

System Contents

Here's what comes with this system (two each):

	6.5 ³ System	6.5 System	5.5 System	4.5 System
 6.5LF woofer	✓	✓		
 5.5LF woofer			✓	
 4.5MR midrange	✓			✓
 Neo 5t tweeter	✓	✓	✓	✓
 Flush-mount kit	✓	✓	✓	✓
 Angle-mount kit	✓	✓	✓	✓
 Surface-mount kit	✓	✓	✓	✓
 Axis-mount kit		✓	✓	
 6.5x crossover	✓			
 6.5x crossover		✓		
 5.5x crossover			✓	
 4.5x crossover				✓

System Placement

Best imaging is obtained when the tweeter and the woofer or midrange are placed out to the sides and far forward.

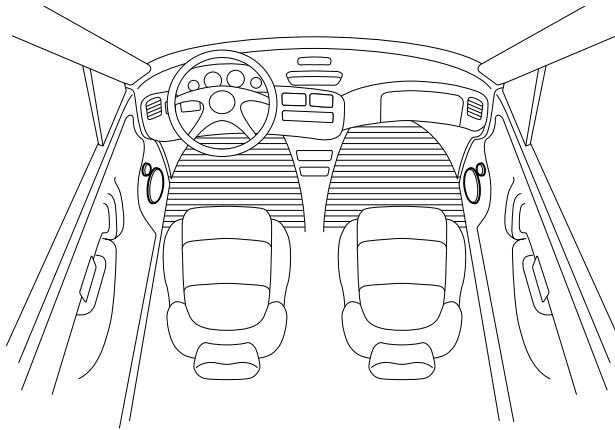

Woofer in door, tweeter in door

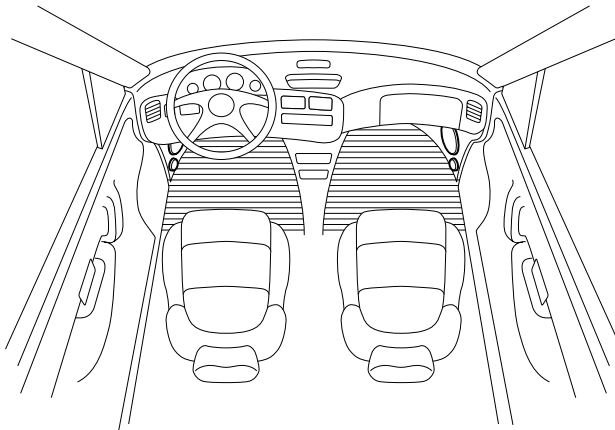

Woofer in kick panel, tweeter in kick panel

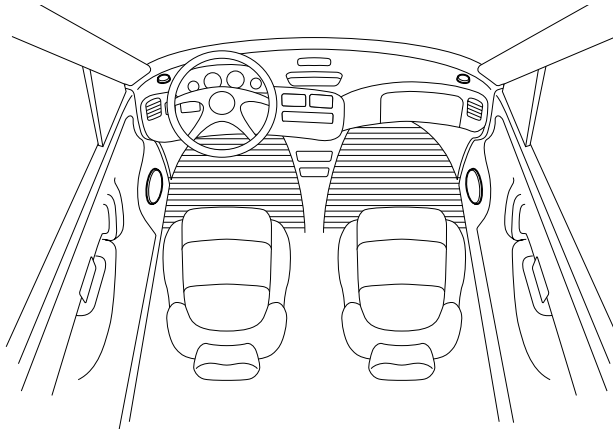

Woofer in door, tweeter in dashboard

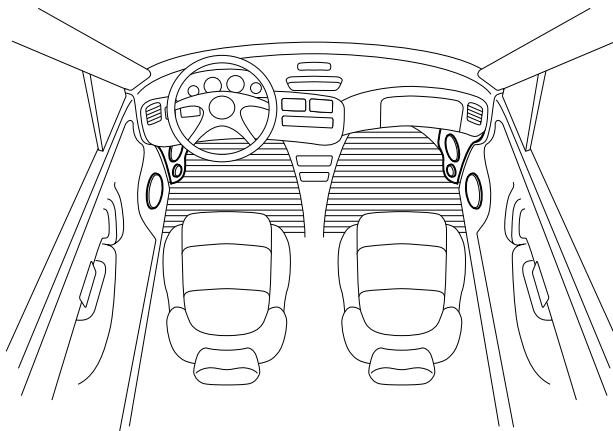

Woofer in door, midrange in kick panel, tweeter in kick panel

Tweeter Installation

There are several different installation kits for the Neo 5t tweeter.

Surface-mount kit



Flush-mount kit

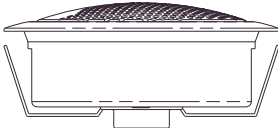

Angle-mount kit

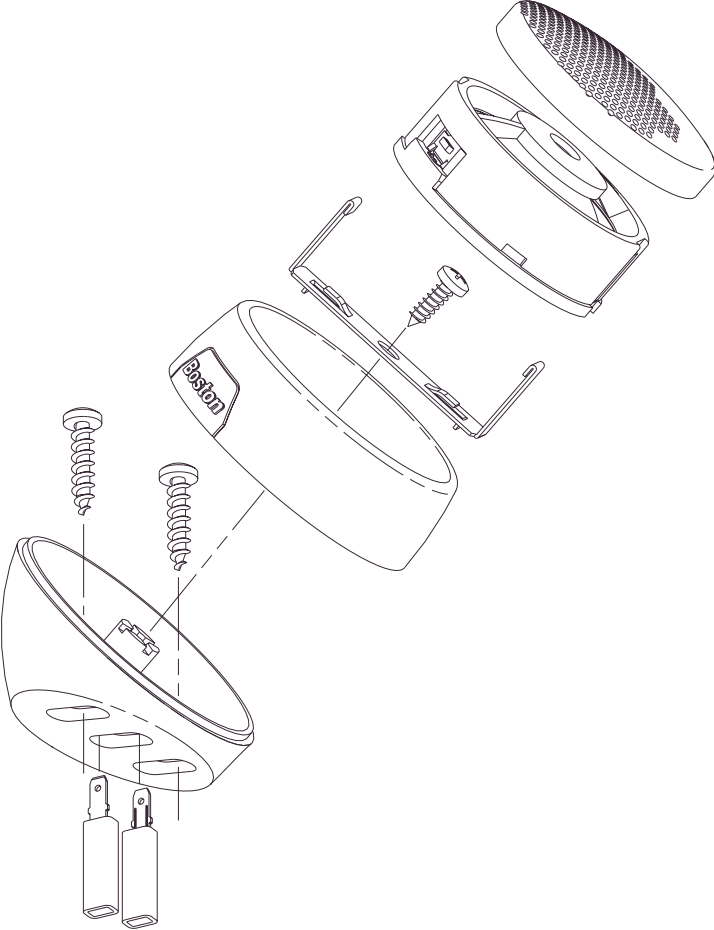
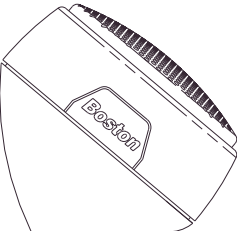

Angle-mount installation

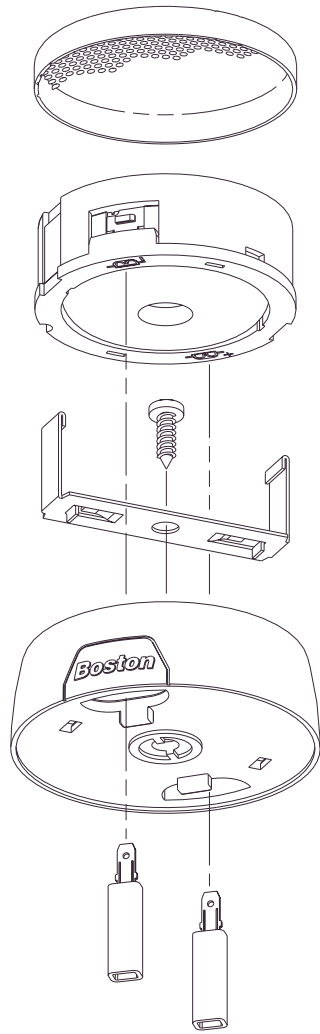

Surface-mount installation

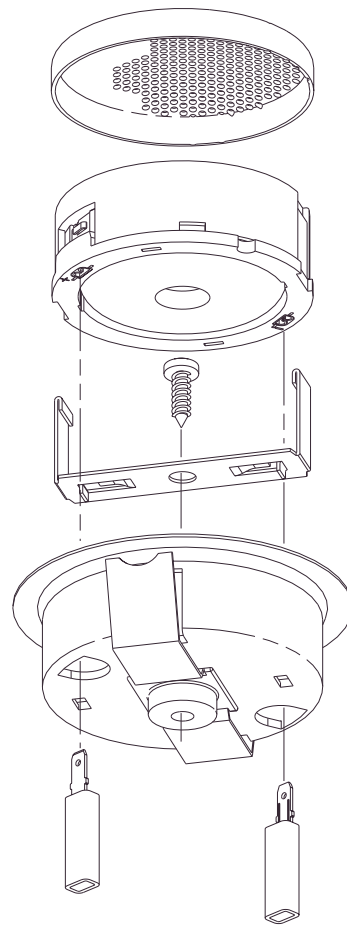

Flush-mount installation

Tweeter Installation—Axis Mount (6.5 & 5.5 systems only)

Axis-mount kit

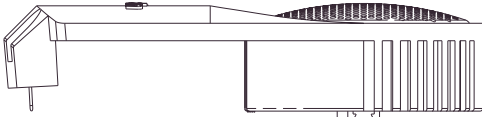

Axis-mount installation

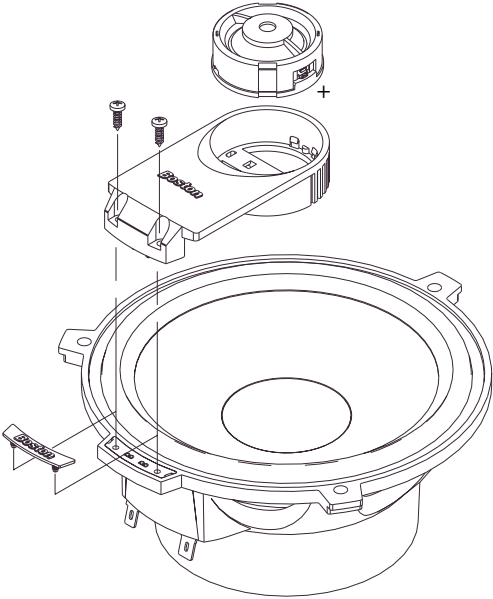

Axis-mount crossover setting

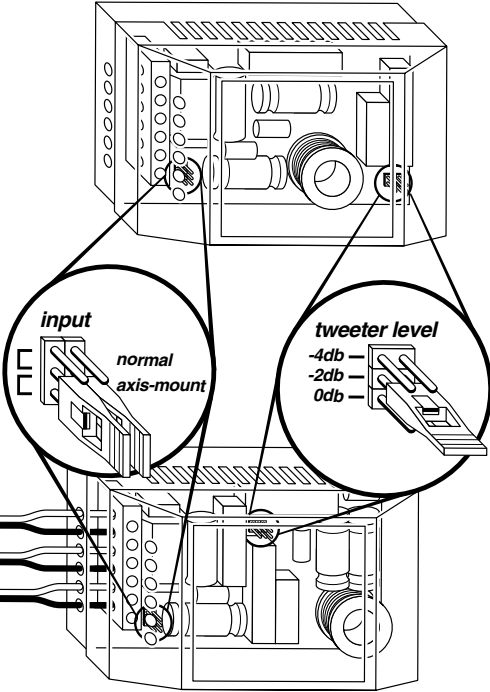

Woofer Installation

Mount the woofer rigidly to a surface that provides a complete air seal from front to rear.

6.5LF installation

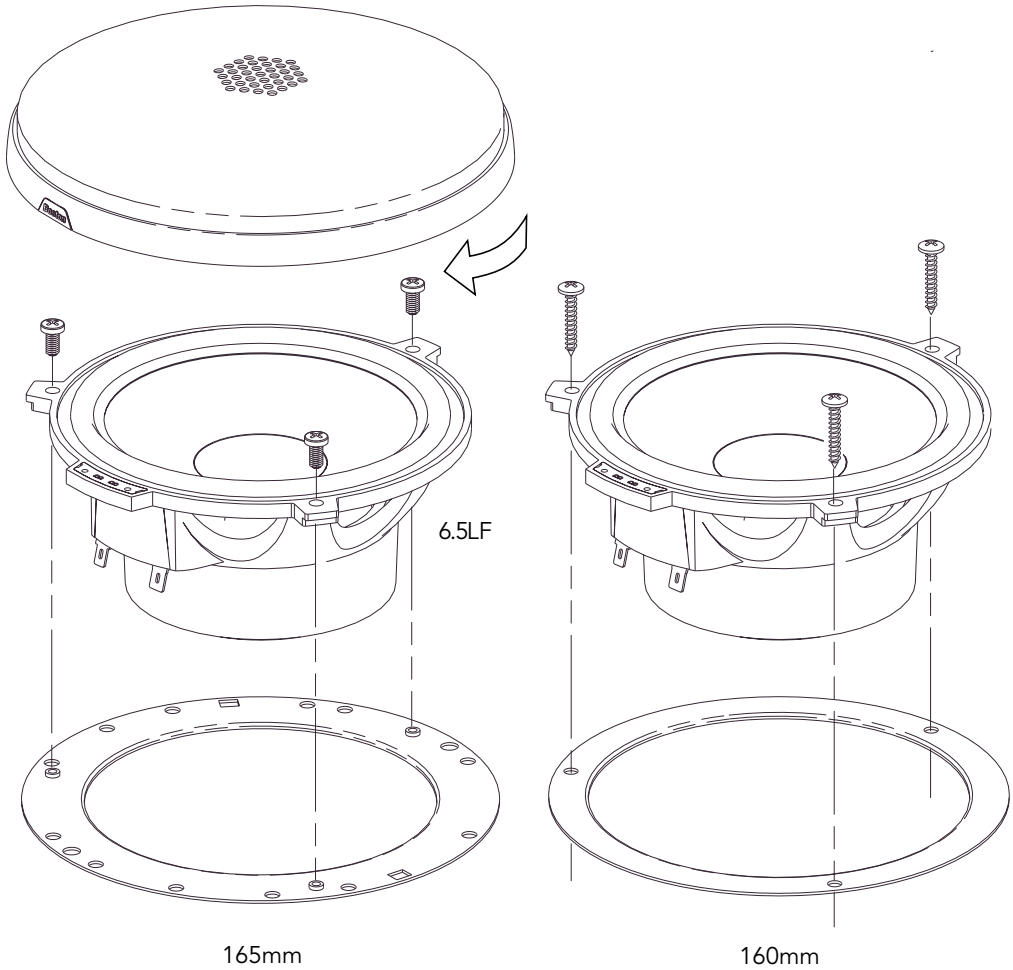

6.5LF installation with spacer

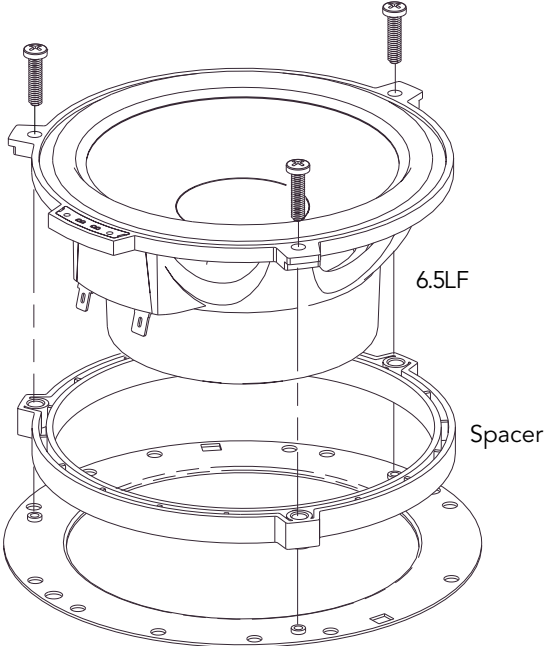

5.5LF installation

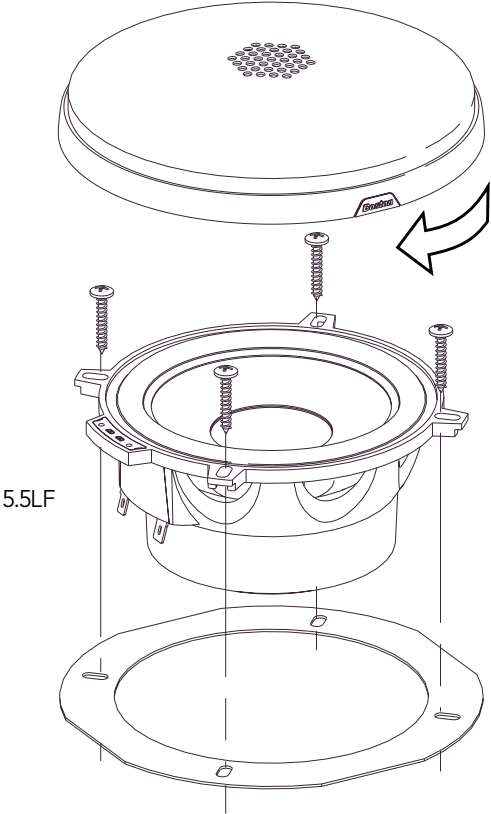

4.5MR installation

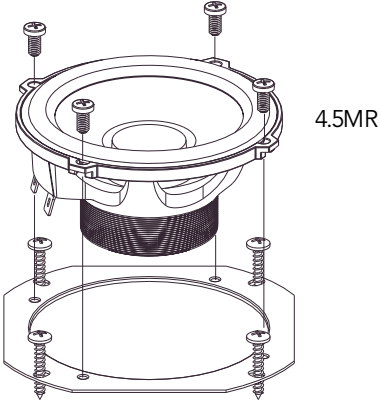
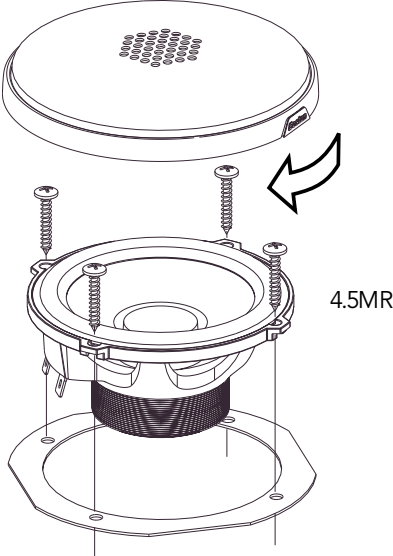

Crossover Installation

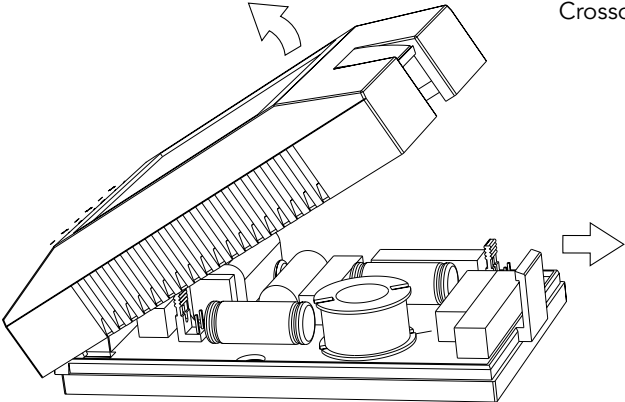

Crossover lid removal

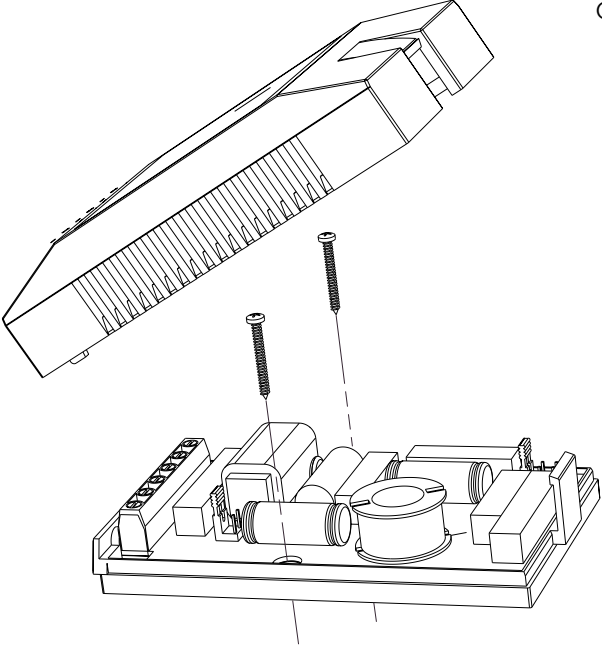

Crossover installation

System Wiring (6.5, 5.5, 4.5 systems)

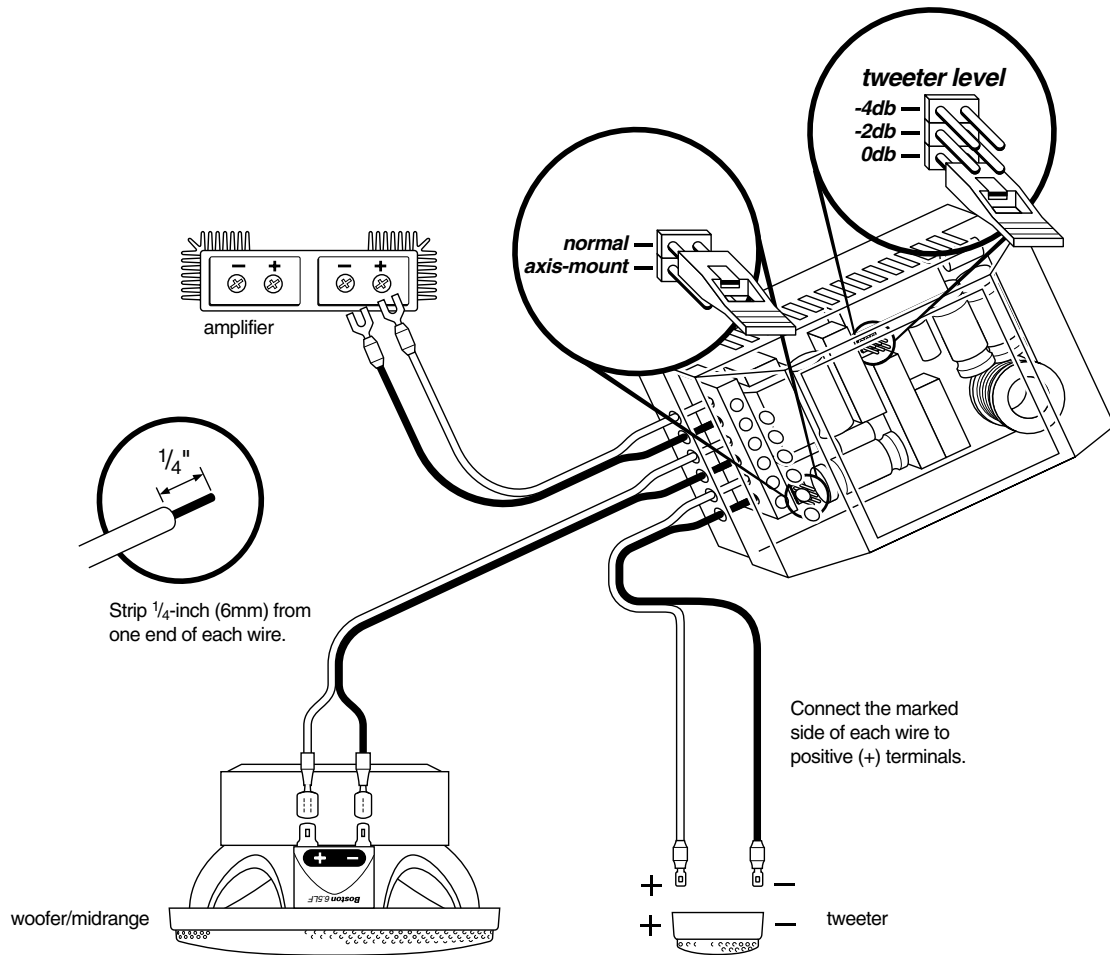

Two-way wiring diagram
6.5/5.5/4.5 systems

System Wiring—Axis Mount (6.5 & 5.5 systems only)

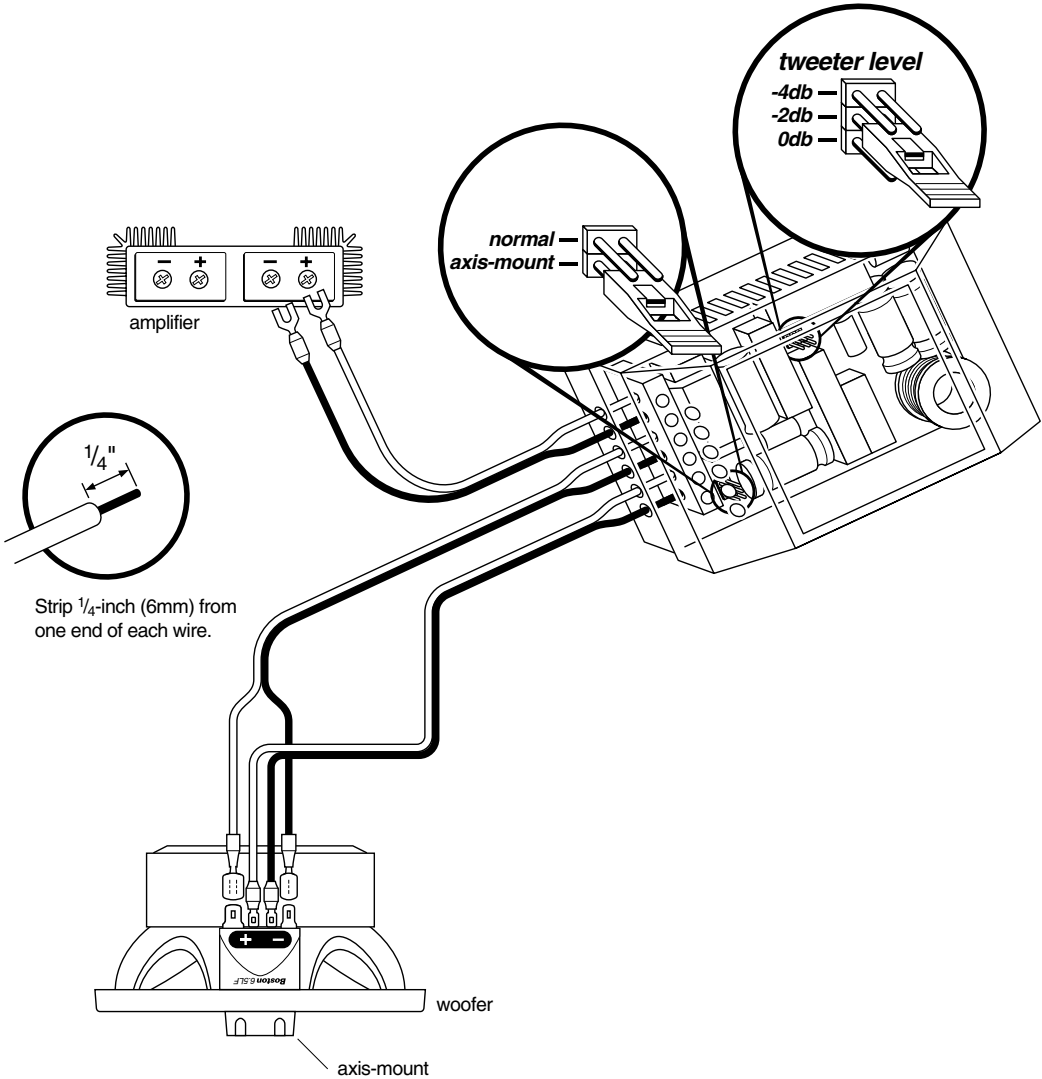

Two-way wiring diagram
6.5/5.5 systems (axis-mount)

Specifications

Specification	6.5 ³ System	6.5 System	5.5 System	4.5 System
Nominal Size (woofer)	6½-inches (165mm)	6½-inches (165mm)	5¼-inches (130mm)	4-inches (100mm)
Mounting Cutout	5-inches (127mm)	5-inches (127mm)	4¾-inches (120mm)	3½-inches (90mm)
Mounting Depth	2⅝-inches (60mm)	2⅝-inches (60mm)	2⅝-inches (59mm)	1¾-inches (43.5mm)
Recommended Amplifier Power	20–500 watts	20–400 watts	20–400 watts	20–300 watts
Frequency Response (±3dB, in-car)	50–22kHz	50–22kHz	60–22kHz	85–22kHz
Nominal Impedance	3Ω	3Ω	3Ω	4Ω
Sensitivity (1watt/1 meter)	90dB	90dB	90dB	87dB

Specifications subject to change without notice.

Boston

300 Jubilee Drive
Peabody, MA 01960
USA
978-538-5000

Boston and Boston Acoustics are registered trademarks of Boston Acoustics, Inc. ©1998

Covered by patents issued and/or pending.

42-789-0