

CRB Mounting Bracket

INSTALLATION INSTRUCTIONS

Note: This mounting bracket is designed for use with the Boston Acoustics CR6 and CR7 loudspeaker systems. Use with any other speakers may result in damage to the speaker system or the mounting surface.

INTRODUCTION

This package contains:

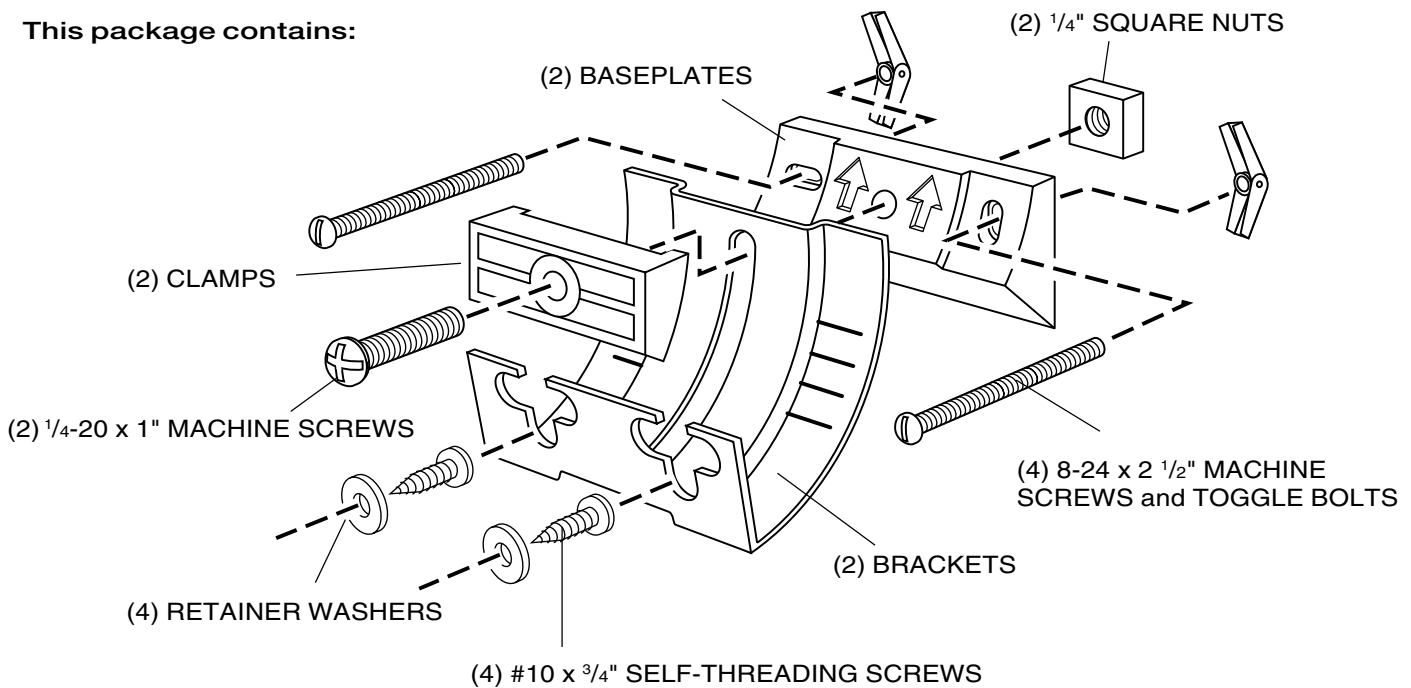

You will need:

1. A drill with a 5/8" (15mm) bit for drilling through the mounting surface, if you are using the supplied toggle bolts.
2. Phillips and flat-head screwdrivers.
3. A level.
4. A pencil.

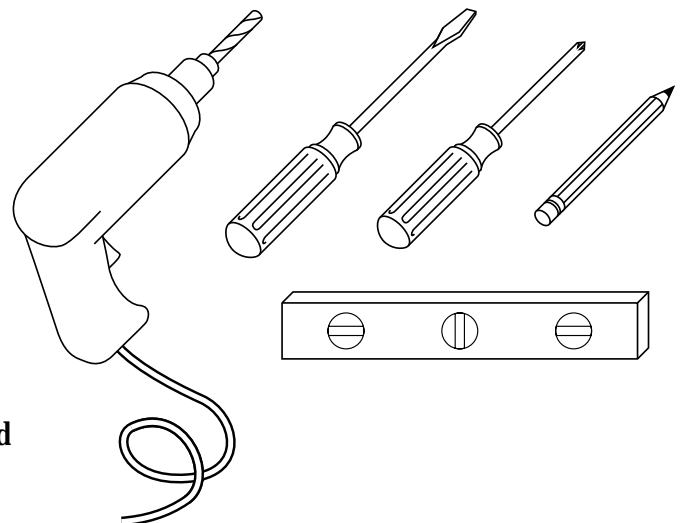

Toggle bolts are supplied for use on drywall or a hollow plaster wall. Alternatively, you may wish to obtain wood screws for wood or wall studs, molly bolts or screw anchors for drywall or plaster, or masonry anchors for masonry.

INSTALLATION

- Determine the mounting orientation.

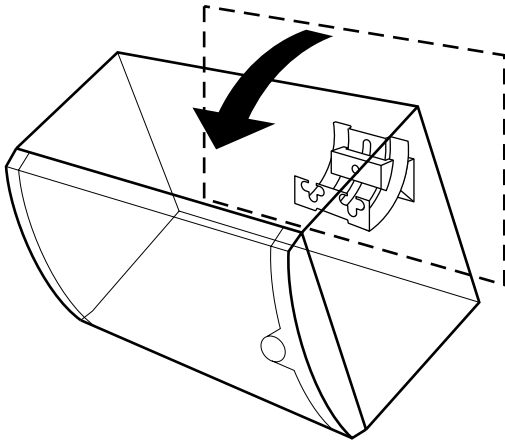

Horizontally, with adjustable tilt downward

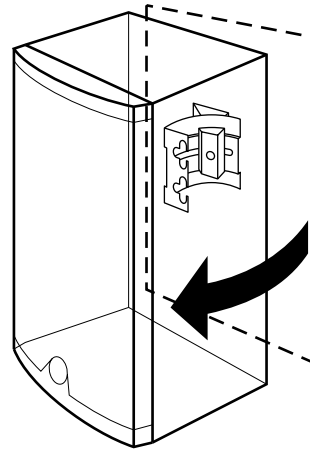

Vertically, with adjustable pivot side-to-side

- Identify the appropriate holes on the back of the speaker for the BRACKET:

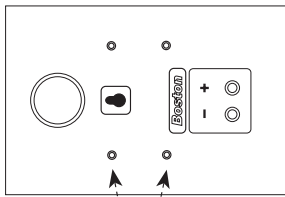

For horizontal mounting, use these holes

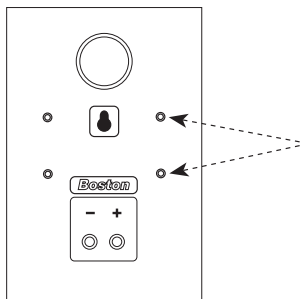
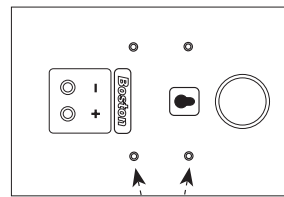

For vertical mounting, use these holes

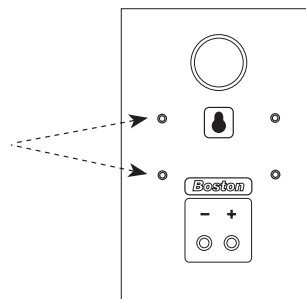

- Install the speaker RETAINER WASHERS:

Install two of the #10 x 3/4" SELF-THREADING SCREWS and matching RETAINER WASHERS into the pair of holes you identified above. Tighten firmly.

CAUTION: USE ONLY THE CORRECT #10 SCREWS SUPPLIED.

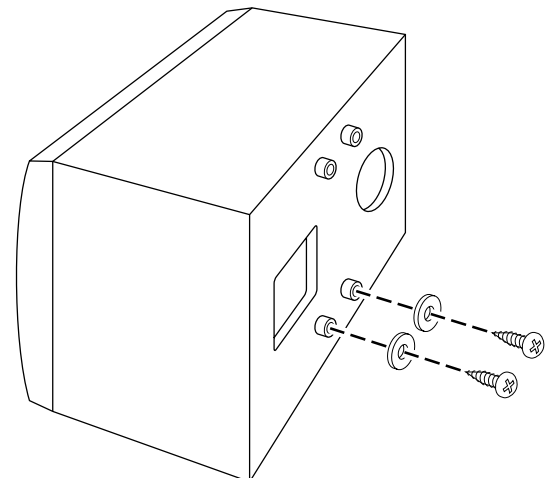

- **Drill the wall holes:**

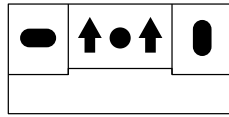
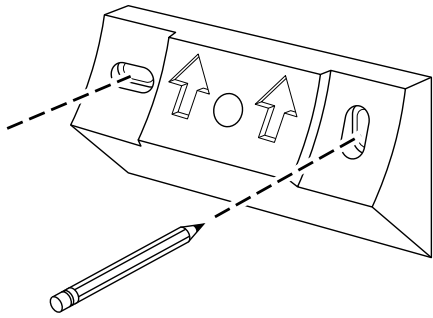

Horizontal mounting- arrows pointing up

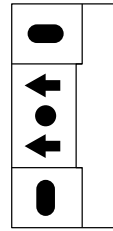

Vertical mounting, left speaker- arrows pointing left

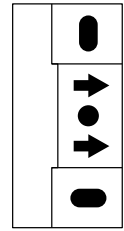

Vertical mounting, right speaker- arrows pointing right

Holding the BASEPLATE in position as a template, mark the centers of the two elongated mounting holes with a pencil. Drill $\frac{5}{8}$ " (15mm) holes in the wall for the supplied toggle bolts.

Fit a SQUARE NUT into the square well on the back of the BASEPLATE. (Use a finger to hold the SQUARE NUT in position until the baseplate is on the wall.)

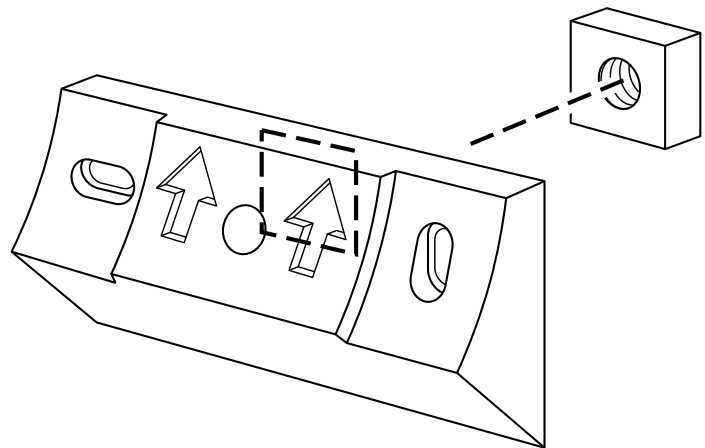

- **Fit the MOUNTING SCREWS onto the BASEPLATE:**

Loosely assemble two long machine screws and two toggle bolts through the elongated mounting holes in either end of the baseplate.

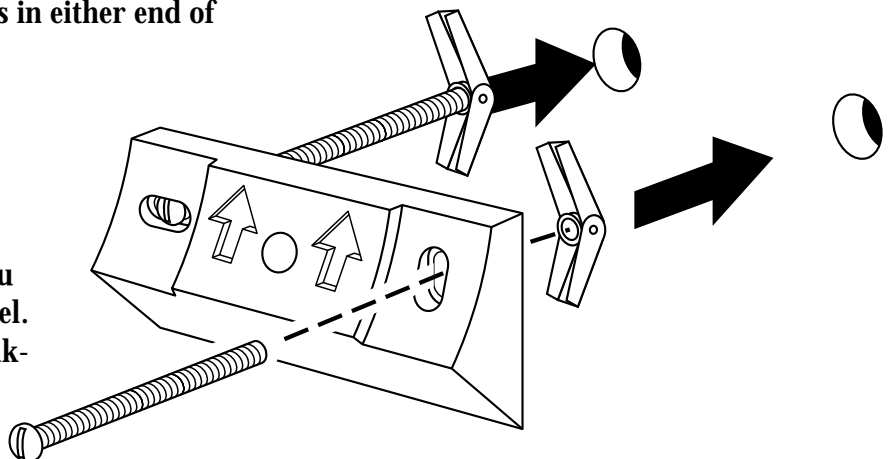

- **Mount the BASEPLATE on the wall:**

Orient the BASEPLATE over the holes you drilled. Make sure the BASEPLATE is level. Tighten MOUNTING SCREWS firmly, making sure TOGGLE BOLTS are properly seated.

- **Fit BRACKET onto BASEPLATE:**

Position BRACKET on baseplate so that BRACKET's plain end (without the flange and T-slots) is toward the direction of arrows on BASEPLATE. Assemble CLAMP over BRACKET so that ribbed (open) side of CLAMP faces up, away from the BRACKET as shown. Align hole in CLAMP with center hole in BASEPLATE, and assemble with 1/4-20 x 1" MACHINE SCREW.

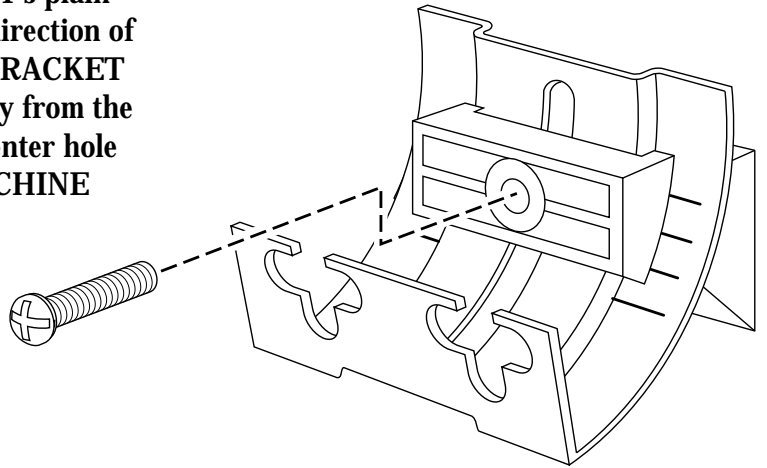

- **Slide BRACKET to desired angle. Then tighten MACHINE SCREW firmly.**

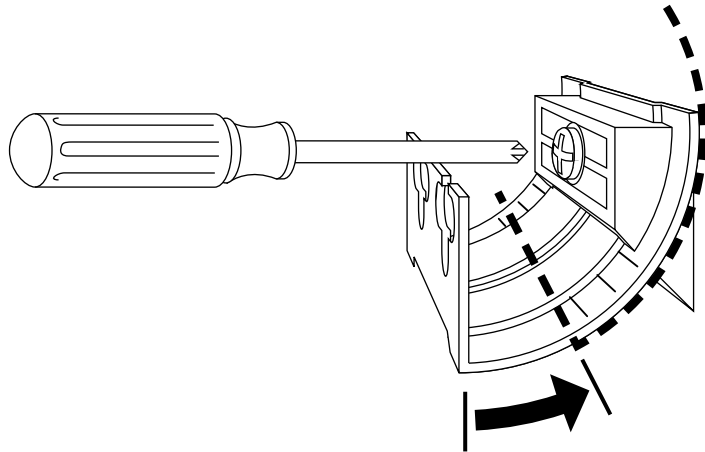

- **Hang speaker on BRACKET:** Hang speaker so that the speaker RETAINER WASHERS fit over flange on end of BRACKET as shown. Wiggle speaker slightly to make sure both of the pins on the speaker are fully engaged into the bottom of the T-slots.

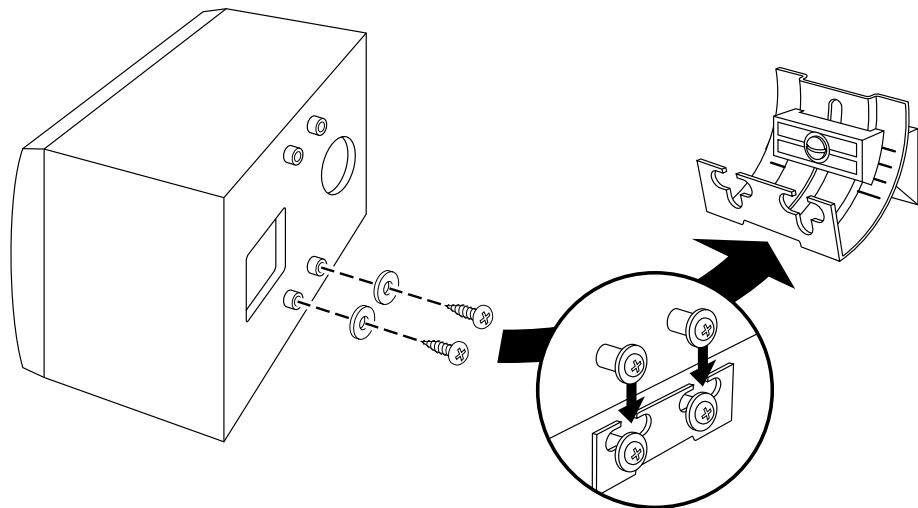

BostonAcoustics
300 Jubilee Drive
Peabody, MA 01960
508-538-5000

Boston and Boston Acoustics are registered trademarks of Boston Acoustics, Inc.
Specifications subject to change without notice.
© 1996 42-550-1